

FERROTACK

General Building Authority Test Certificate



Properties:

FERROTACK is a metal waterstop manages without the need of elaborate concrete upstands. It is simply mounted on top of the upper reinforcement and fixed with clips or clamps.

Contrary to conventional metal waterstops *FERROTACK* is only 15 - 17 cm high and available in rolls or strips. The independent adhesion of the butyl rubber to the concrete compensates for the shorter circular stretch of the upright steelplate when mounted.

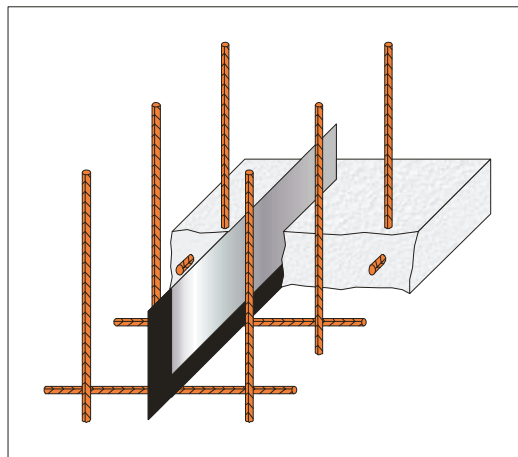

Compared to metal waterstops coated with polymer modified bitumen *FERROTACK* provides some technical advantages. Butyl rubber is a vulcanized synthetic material and has no thermoplastic characteristics such as bitumen. Therefore, *FERROTACK* is much easier to process at very high and low temperatures in contrast to bitumen-coated metal waterstops.

Technical data:

Metal type	Slit strip, type DC01 A
Rubber type	Butyl rubber, vulcanized
Coating type	
FERROTACK I	stripe-coated on the underside
FERROTACK II	stripe-coated circulating
FERROTACK VB I	one sided fully coated
FERROTACK VB II	double sided fully coated

Processing:

FERROTACK must always be installed with the self-adhesive facedown to the water (one-side coated products).

The metal waterstop is either mounted on top of the upper reinforcement before concreting or inserted immediately after concreting, deep enough so that the waterstop is minimum 30 mm covered by concrete.

The connection of individual metal waterstops is performed by means of fixing clamps or fastening clips.

It must be ensured that the adhesive bonds are jointed together under pressure.

Due to the chemical properties of butyl rubber *FERROTACK* can be processed at low temperatures without prior heating of the coating.

When *FERROTACK* is applied for sealing of precast double walls the use of *FERROTACK-Stoß* and *FERROTACK-Eck* is recommended for sealing of vertical joints between the individual walls and in the corners.

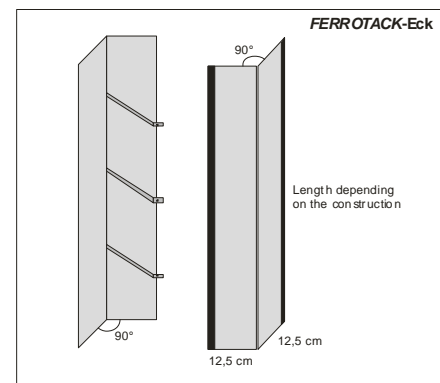
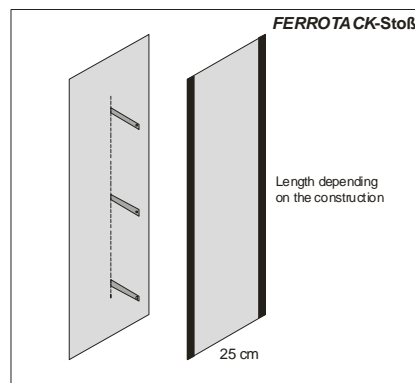

FERROTACK-Stoß and *FERROTACK-Eck* vertical joint elements are placed on the base plate and bonded to the horizontal *FERROTACK* joint metal waterstop and fixed each with two fixing clamps type VF. Furthermore the fixing devices of *FERROTACK-Stoß* and *FERROTACK-Eck* are fastened with dowels to the precast double wall.

Application of *FERROTACK-Stoß*:

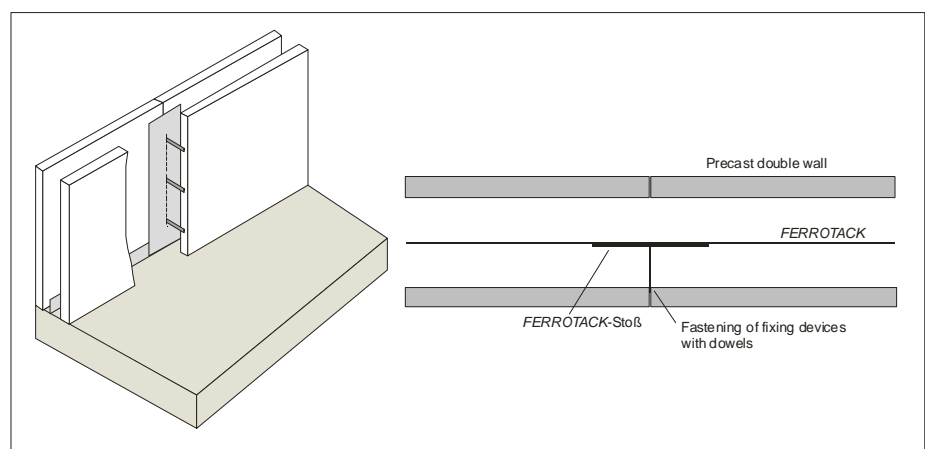

Application of *FERROTACK*-Eck:

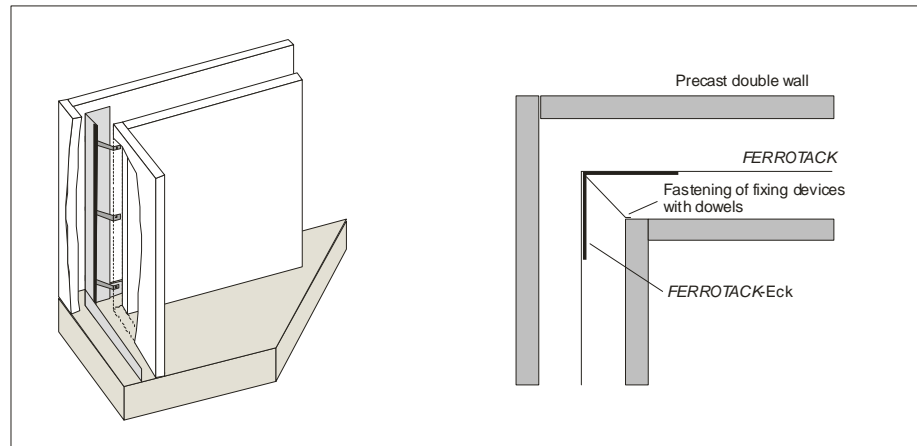

Safety information:

No special measures required

Packaging:

2 m stripe 50 m in package
20 m roll 20 m in carton

Further information on packaging of different *FERROTACK* types please refer to the price list.

Storage:

Shelf life at least 24 month in original packaging when stored in dry conditions between 15-25°C, protected from heat, frost and direct sunlight.

After the expiration the use of the product is generally not recommended, unless an approval has been provided by TPH. This approval can only be obtained by the quality assurance department of TPH releasing the material after verification of main properties being within specification.

Disposal:

Recommendation:

Small quantities of product residues can be disposed of as normal domestic waste. Dispose of bigger quantities must be effected in accordance with the corresponding local regulations.

Test certificates:

General Building Authority Test Certificate for *FERROTACK* metal waterstop and *FERROTACK* vertical joint element; MFPA Leipzig 2009



Legal notice:

The correct and thus successful application of our products is not subject to our control. A guarantee can be issued for the quality of our products within the framework of our sales and supply conditions, however not for successful processing. All data and specifications in this specification sheet are based on the present state of the art and the right to changes and adaptations for the sake of development remains explicitly reserved. The consumption specifications designated by us can be only average empirical values, where deviations are possible on an individual basis and therefore cannot be excluded by us.

TPH Bausysteme GmbH
Nordportbogen 8
D-22848 Norderstedt

Tel.: +49 (0)40 / 52 90 66 78-0
Fax: +49 (0)40 / 52 90 66 78-78
e-mail info@tph-bausysteme.com
Web www.tph-bausysteme.com

